

Technology trends

The following are the key technology trends in EVs that was covered in the lecture:

Electric vehicle powertrain design

1. Amongst EV manufacturers, it has now become unofficially recognized that EVs in the future must have a battery capacity that can provide 200-300 mile range.
2. Secondly, manufacturers are moving towards designing electric vehicles from the bottom up rather than building them based on existing combustion engine cars.
3. A third trend is to integrate the different powertrain components and controllers in the vehicle.

Battery technology

On the battery side, a vital parameter to realize more efficient EVs in the future is energy density. We saw in the lecture that there is theoretically up to a five-fold potential to go from the current Lithium-ion energy density of 200Wh/kg to up to 1000Wh/Kg possible with lithium-air batteries. There is hence a huge potential for research into the materials, stability, safety, cycle life, power and energy density and manufacturability of these emerging battery technologies. Besides this, supercapacitors can provide high power densities when used in collaboration with a battery for peak powers requirements during acceleration and braking.



This course material is licensed under a Creative Commons Attribution-NonCommercial-ShareAlike 4.0 License.

Solar Electric Vehicles



Nuna 8 Solar race car
Delft University of Technology



Stella Solar family car
Eindhoven University of Technology

In the pictures, you can see the solar powered electric vehicles Nuna and Stella designed by student teams at the Delft University of Technology and Eindhoven University of Technology from the Netherlands. While the Nuna is a designed to be a race car, the Stella is a family car. The common feature in both vehicles is that solar panels are used for charging the onboard battery and provides practically all the energy needed for driving.

While providing all the power requirements of a commercial electric car using onboard solar cells would not be possible in the near future, several EV manufacturers have announced to have solar cells integrated into the car roof. This will partially provide the driving energy, thereby extending the car range.



This course material is licensed under a Creative Commons Attribution-NonCommercial-ShareAlike 4.0 License.

Solar electric vehicles: power flow

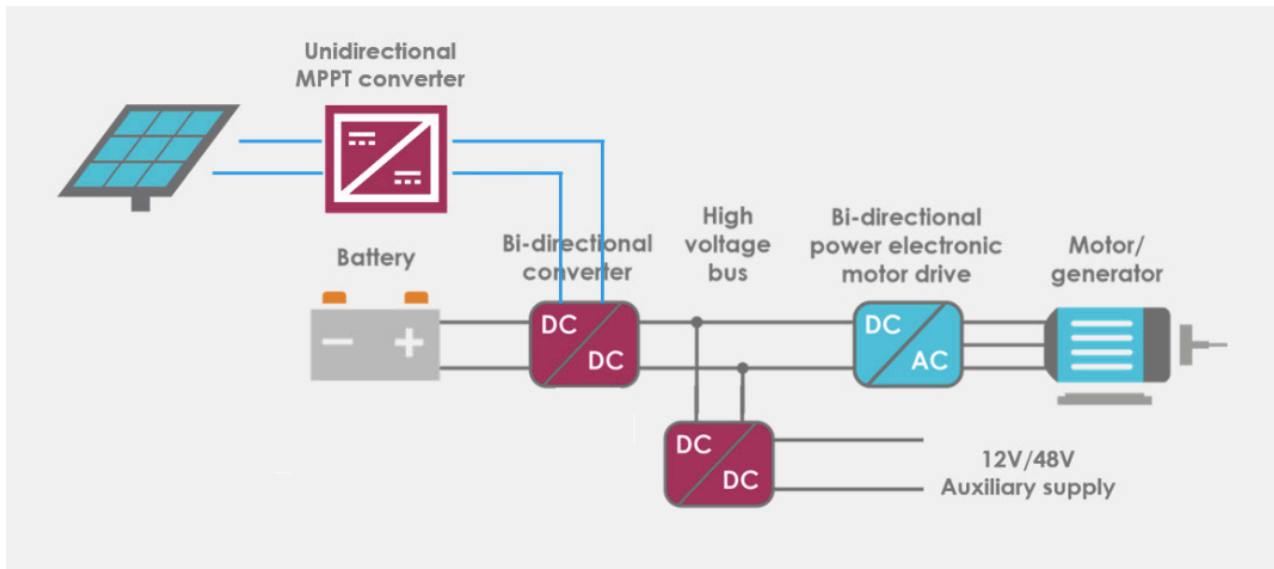

In case of a solar electric vehicle, solar panels are included in the drive train through a maximum power point tracking or MPPT, DC to DC power converter. This converter ensures that solar array is operated at its optimal power point and the voltage of the PV array is matched with that of the high voltage bus inside the EV.

Solar electric vehicles

Fuel cells powered by hydrogen can provide long driving range and quick fuelling times similar to a combustion engine vehicle. A fuel cell electric vehicle is essentially an electric vehicle with a battery with the key feature of using a fuel cell to charge the battery and power the drivetrain. Production versions of fuel cell vehicles



This course material is licensed under a Creative Commons Attribution-NonCommercial-ShareAlike 4.0 License.

have been offered by several leading car manufacturers including Toyota, Honda, Hyundai, and Mercedes. While high costs of the vehicle and charging infrastructure have limited its growth till now, fuel cell EVs are expected to emerge back in the future and play a key role especially for long distance heavy vehicle transport such as trucks.

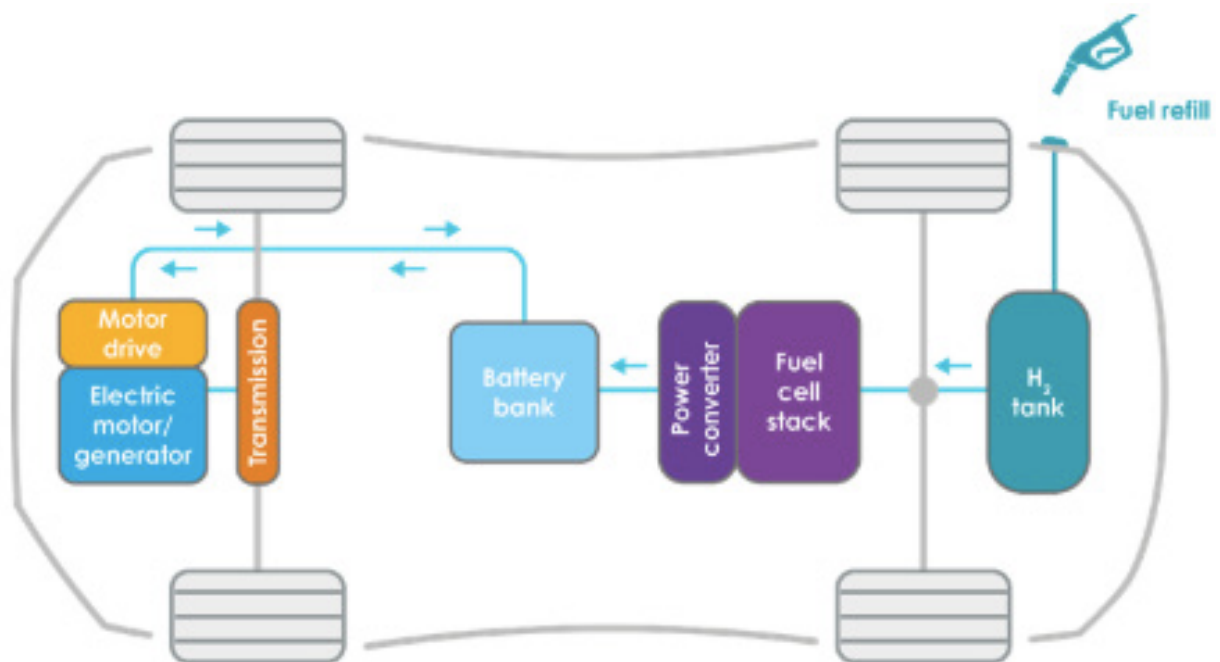

This course material is licensed under a Creative Commons Attribution-NonCommercial-ShareAlike 4.0 License.

Future of EV charging:

1. Battery swap

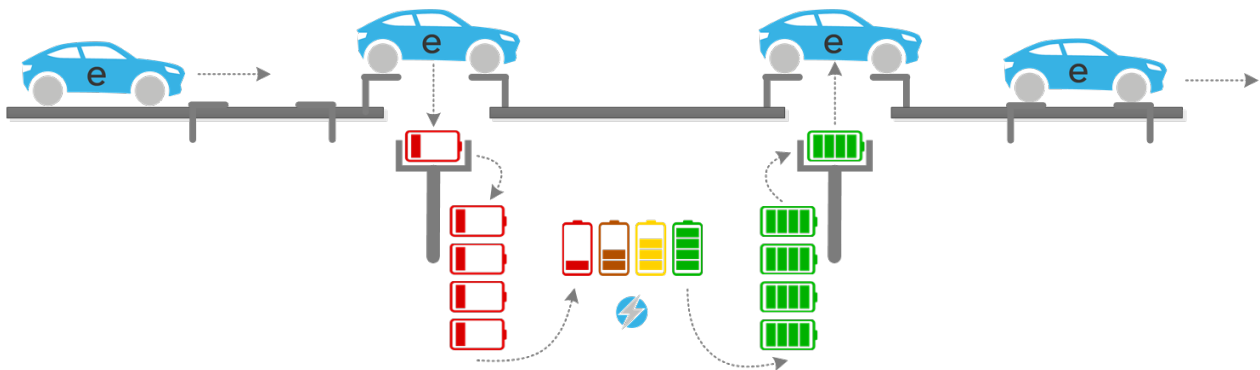

This charging technology works on the basis of switching out the depleted battery of an EV and replacing the same with a full battery. The most important advantages of battery swap are the fast times to replenish an empty battery and the flexibility to charge the battery at the swap station over a longer time when compared to fast charging. However, the main challenge for battery swap comes from the vehicle design. Large-scale adoption of battery swap technology requires EVs to be designed with a standardized battery, battery interface and vehicle chassis that allows easy removal, charging and placement of the batteries back to the vehicle.



This course material is licensed under a Creative Commons Attribution-NonCommercial-ShareAlike 4.0 License.

2. Wireless charging

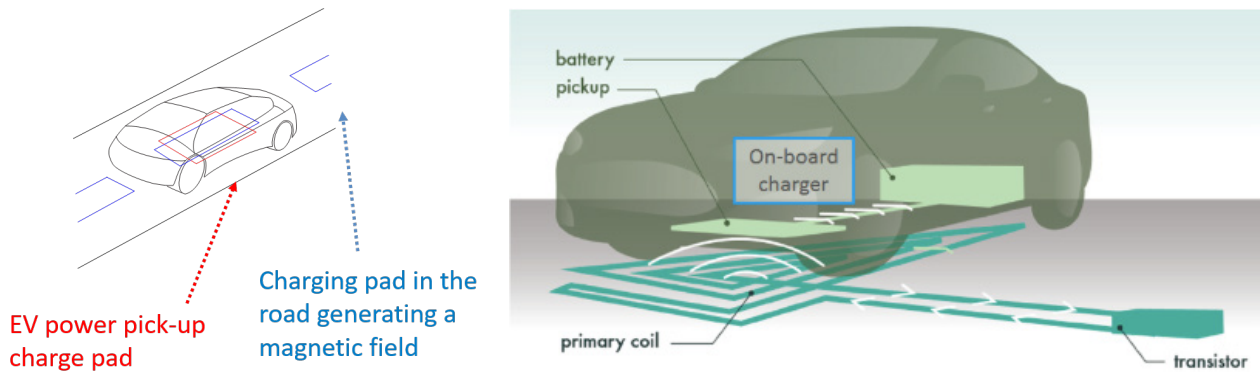

The inductive wireless charging of electric vehicles would provide ease and convenience of charging without the requirement of any charging cables. The technology uses two electromagnetically linked coils that exchange power at high frequency. The primary coil is placed on the road surface and linked to the electricity network while the secondary coil is placed on the vehicle and charges the battery. Wireless charging systems are now commercially available for various electric vehicles.

The extension of wireless charging would be on-road charging where inductive charge pads are placed along the roads so that electric cars can wirelessly charge while driving. It's a technology that can dramatically reduce the cost of electric cars as they would need a smaller battery and move this cost to the charging infrastructure.



3. Smart charging

The third key charging technology is smart charging (especially from renewable sources of energy like wind and solar) and vehicle to grid technology. Smart charging of EVs whether it is AC, DC or wireless involves the control of the charging power as a function of time.

By controlling the charging power, several benefits can be achieved in the future namely:

- Reducing the charging cost.
- Charging based on renewable energy generation.
- Using the car as a storage for the renewables and a grid back up with the use of vehicle-to-grid.
- Providing demand-side management and reducing the peak load and losses in the distribution network.
- Providing ancillary services in the form of voltage and frequency control to the grid.

Example of V2X: V2X project in the city of Amsterdam

The city of Amsterdam has been making a demonstration of the vehicle to grid concept. In this project, running from 2014-2017, 2 well working Vehicle 2 Home installations were installed in the city. Partners cooperating in this project were Engie, Alliander, Mitsubishi Motors, Amsterdam Smart City and Amsterdam University of Applied Sciences. RVO provided a subsidy via TKI Switch 2 Smart Grids. This video made by Amsterdam smart city on V2G gives an overview of the pilot



This course material is licensed under a Creative Commons Attribution-NonCommercial-ShareAlike 4.0 License.

done in Amsterdam, the lessons learned and the challenges faced. The video is in Dutch with English subtitles.

To learn more about the project, you can visit, <https://amsterdamsmartcity.com/projects/vehicle2grid>.

Autonomous driving

Self-driving with limited capabilities have already been built into existing electric cars such as those from Tesla. Self-driving vehicles open up a plethora of opportunities in the future such as shared and connected mobility, cities decongested of cars and parking spaces, higher utilization of vehicles, lower cost of mobility and more efficient point-to-point connectivity. A combination of different kinds of sensors such as a video camera, Light detection and ranging or LIDAR, Radar sensors, Ultrasonic sensors, and GPS are used by the vehicles to understand the environment, and a computer on board controls the movement of the car.

Autonomous driving is expected to be developed over 5 levels starting at Level 1 where the car can control either the steering or speed under certain conditions to Level 5 where the car can autonomously drive itself under all conditions.



This course material is licensed under a Creative Commons Attribution-NonCommercial-ShareAlike 4.0 License.

Example of autonomous driving: Tesla Autopilot



Source: Tesla autopilot (www.tesla.com)

To experience how it is to sit inside a (partial) autonomous vehicle, let's look at the Autopilot system of a commercial car available today, namely the Tesla Model S EV. The EV uses eight cameras that provide 360 degrees of visibility around the car, twelve ultrasonic sensors, and a front-facing radar to gather information about the surroundings. Kindly click on the image above to learn about the sensors used on board the Tesla car and see a 2 min video showing the view from the driver's seat.



This course material is licensed under a Creative Commons Attribution-NonCommercial-ShareAlike 4.0 License.